



DELTA

**Inspire Ultra SMV Series
Branch Module #5**

**89FBMJ205
89FBMJ215**

INSTRUCTION MANUAL

WARNING!

Read and follow all safety precautions in Instruction Manual - improper use can cause serious injury.

Preface

Inspire Ultra Inverter S16 Series Systems adopt the advanced manufacturing technology and takes the environmental-friendly R410A as refrigerant, which is a green product in the 21st century. Please carefully read the manual before installation and operation.

- ◆ The total capacity of the indoor units which runs at the same time cannot exceed the capacity of the outdoor units; otherwise, the cooling (heating) effect of each indoor unit would be lower than the nominal capacity.
- ◆ Make sure that the manual is kept by the operators or serviceman.
- ◆ The refrigerant pipes and accessories must be designed exclusively for R410A.
- ◆ It is a normal phenomenon that the fan of indoor unit will still run for 20~70 seconds after the indoor unit receives the “stop” signal so as to make full use of the waste heat.
- ◆ When the work mode of the indoors is conflict with the modes of outdoor units, it will be indicated on the display of the wired controller in five seconds and then the indoor unit will stop. In this case, please harmonize their work modes: the cooling mode is compatible with the dry mode.
- ◆ If the supply power fails when the unit is running, then the indoor unit will send the “start” signal to the outdoor unit three minutes after the power recovery.
- ◆ The power cable and transmission line must not be twisted together, but instead of separated with an interval of at least 2cm; otherwise it may be result in communication problem.
- ◆ This appliance is not intended for use by persons (including children) with reduced physical, sensory or mental capabilities, or lack of experience and knowledge, unless they have been given supervision or instruction concerning use of the appliance by a person responsible for their safety. Children should be supervised to ensure that they do not play with the appliance.
- ◆ Cautions for the debugging and maintenance personnel:
During debugging and maintenance, before the startup of the compressor, Please make sure that the crankcase heater of the compressor has been energized for at least eight hours! Once the compressor is started, it must be guaranteed that it works continuously for at least 30 minutes, otherwise it would be damaged!



This product must not be disposed together with the domestic waste. This product has to be disposed at an authorized place for recycling of electrical and electronic appliances.

Thank you for purchasing Delta air conditioners. Before using, please read this manual carefully and keep it properly for further reference.

Contents

1	Safety Precautions.....	1
2	Product Introduction.....	3
2.1	Names of Main Parts.....	3
2.2	Combinations for Outdoor and Indoor Units.....	3
2.3	Parts and Components of Unit.....	4
2.4	Working Temperature Range.....	4
3	Selection of Installation Location and Precautions.....	5
3.1	Selection of Installation Location.....	5
3.2	Outline Dimension and Servicing Space.....	6
4	Installation Instruction.....	7
5	Installation of Refrigerant Pipes.....	8
5.1	Allowable Length and Drop Height of Connecting Pipe.....	8
5.2	Installation of Piping Adapter.....	8
5.3	Precaution for Connection.....	9
6	Electrical Wiring Work.....	11
6.1	Wiring Connection.....	11
6.2	Requirements of Power Circuit and Cable.....	12
6.3	Ground Requirements.....	12
6.4	Precautions of Electrical Wiring Work.....	13
6.5	Precaution of Laying Wires.....	13
6.6	Procedures for Electrical Wiring Work.....	13
6.7	Instructions for DIP Switch.....	15
7	Design of Drainage Pipeline.....	16
7.1	Installation of Drain Hose.....	16
7.2	Design of Drainage Pipeline.....	16
8	Test Operation.....	16
9	Troubleshooting.....	17
10	After-Sales Service.....	18

1 Safety Precautions



Warning! : It indicates improper operation might lead to human casualty or sever injury



Caution! : It indicates that improper operation might lead to personal injury or property damage.



Follow this instruction to complete the installation work. Please carefully read this manual before unit startup and service.



Installation should be conducted by dealer or qualified personnel. Please do not attempt to install the unit by yourself. Improper handling may result in water leakage, electric shock or fire disaster etc.

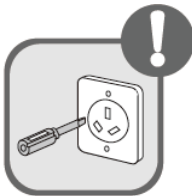

Before installation, please check if the power supply is in accordance with the requirements specified on the nameplate. And also take care of the power safety.



Make sure the unit can be earthed properly and soundly after plugging into the socket so as to avoid electric shock. Please do not connect the ground wire to gas pipe, water pipe, lightning rod or telephone line.



Be sure to use the exclusive accessory and part to prevent the water leakage, electric shock and fire accidents.



If refrigerant leakage happens during installation, please ventilate immediately. Poisonous gas will emerge if the refrigerant gas meets fire.



Wire size of power cord should be large enough. The damaged power cord and connection wire should be replaced by exclusive cable.

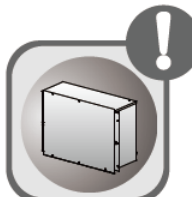

After connecting the power cord, please fix the electric box cover properly in order to avoid accident.

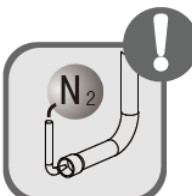

Never fail to comply with the nitrogen charge requirements. Charge nitrogen when welding pipes.



Never short-circuit or cancel the pressure switch to prevent unit damage.



Please firstly connect the wired controller before energization, otherwise wired controller can not be used.



Before using the unit, please check if the piping and wiring are correct to avoid water leakage, refrigerant leakage, electric shock, or fire etc.



Do not insert fingers or objects into air outlet/inlet grille.



Open the door and window and keep good ventilation in the room to avoid oxygen deficit when the gas/oil supplied heating equipment is used.



Never start up or shut off the air conditioner by means of directly plug or unplug the power cord.



Turn off the unit after it runs at least five minutes; otherwise it will influence oil return of the compressor.



Do not allow children operate this unit.



Do not operate this unit with wet hands.

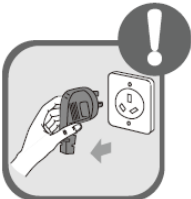

Turn off the unit or cut off the power supply before cleaning the unit, otherwise electric shock or injury may happen.



Never spray or flush water towards unit, otherwise malfunction or electric shock may happen.



Do not expose the unit to the moist or corrosive circumstances.



Electrify the unit 8 hours before operation. Please switch on for 8 hours before operation. Do not cut off the power when 24 hours short-time halting (to protect the compressor).

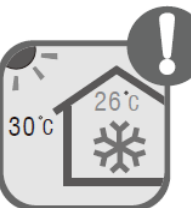

Under cooling mode, please don't set the room temperature too low and keep the temperature difference between indoor and outdoor unit within 5°C.

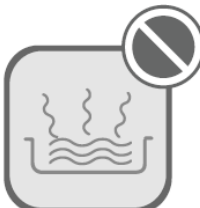

Volatile liquid, such as diluent or gas will damage the unit appearance. Only use soft cloth with a little neutral detergent to clean the outer casing of unit.



If anything abnormal happens (such as burning smell), please power off the unit and cut off the main power supply, and then immediately contact Delta appointed service center. If abnormality keeps going, the unit might be damaged and lead to electric shock or fire.



User is not allowed to repair the unit. Fault service may cause electric shock or fire accidents. Please contact Delta appointed service center for help.

Delta is not responsible for personal injury or equipment damage caused by improper installation and start up, unnecessary service and not following the rules and instructions listed in the manual.

2 Product Introduction

The BM module of Delta Inspire Inverter S16 Series is the latest branch device, which adopts the intelligent control technology. Respond to the changes in load of the indoor units, it can coordinate the flow rate of the refrigerant well. Otherwise, it is very compact and has a flexible choice about the installation location, such as the ceiling of parlor, corridor, balcony, storeroom and etc.

2.1 Names of Main Parts

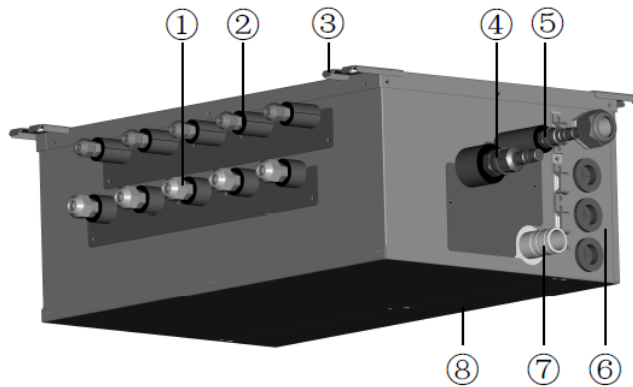

89FBMJ205

NO.	①	②	③	④
Name	Gas piping of indoor unit side	Liquid piping of indoor unit side	Hanger metal	Gas piping of outdoor unit side
NO.	⑤	⑥	⑦	⑧
Name	liquid piping of outdoor unit side	Electrical box	Drain hole	Electrical equipment plate

Fig. 1

2.2 Combinations for Outdoor and Indoor Units

Table 1

Sorts		89FBMJ205
No. of connectable indoor units	Min	1
	Max	5

2.3 Parts and Components of Unit

For the super free match series, one outdoor unit is able to drive up to three BM modules and nine indoor units which include cassette type, duct type, wall mounted type, floor ceiling type and console type. The outdoor unit will run as long as any one indoor unit receives the running command, and all indoor units stop once the outdoor unit is turned off.

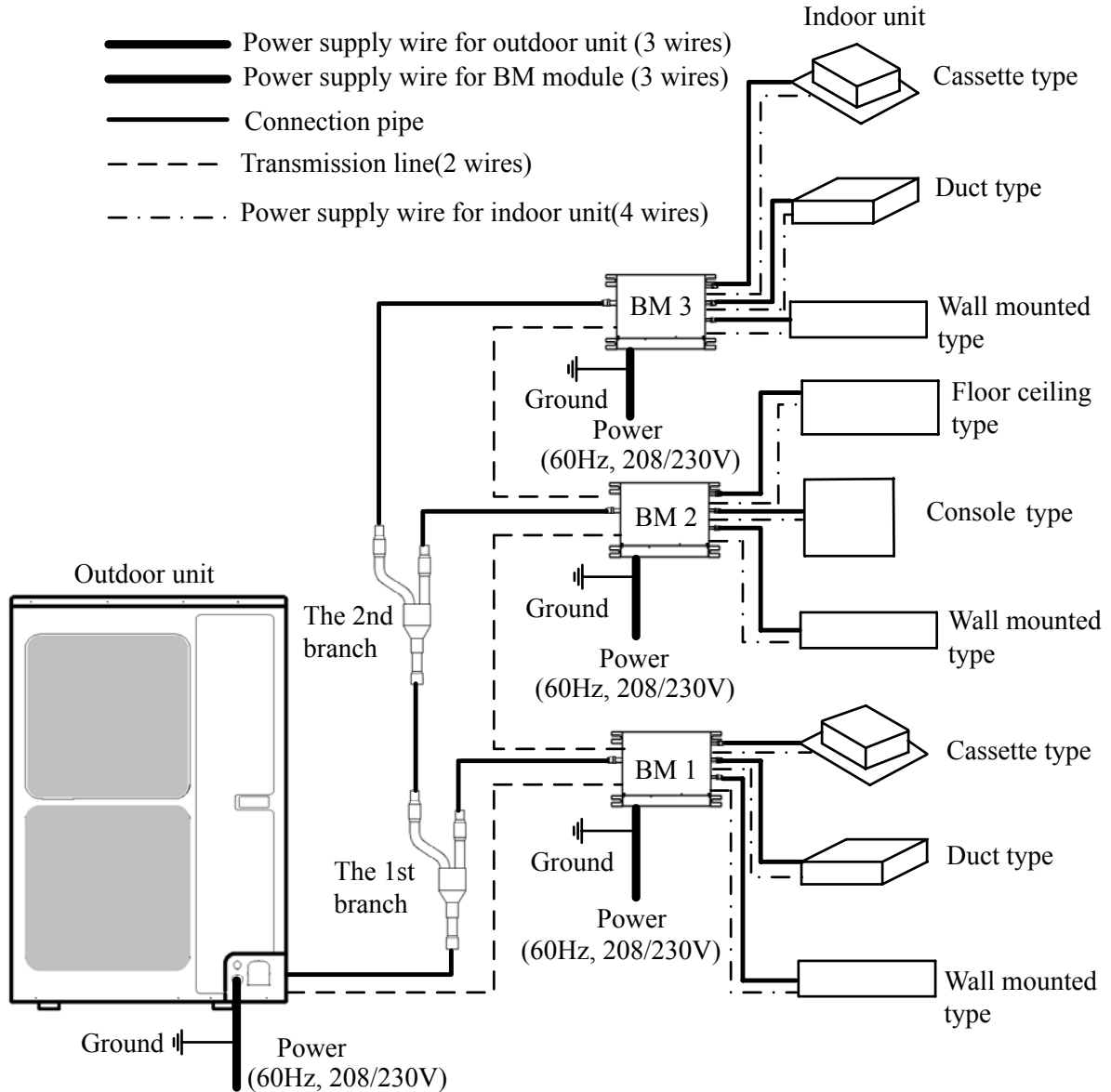

Fig. 2

2.4 Working Temperature Range

Table 2

Sorts	Outside temperature DB/WB(°C)
Maximum	50/-
Minimum	-15/-

3 Selection of Installation Location and Precautions



Caution!

- ◆ The installation of the air conditioner must be in accordance with the national and local laws and regulations.
 - ◆ The quality of the installation will affect the capability of air conditioner directly. The installation should be left to the appointed service center. Please contact your dealer after purchasing this machine. Professional installation workers will provide installation and test services according to the installation manual.
 - ◆ The air conditioner should not install in this place where the small animals exist, because they may cause malfunctions, smoke or fire. Please keep the area around the unit clean.
-

3.1 Selection of Installation Location

- ◆ The BM module is for indoor use. If installing in the outdoors, the location must be away from wind and rain. Otherwise, it may cause water leakage, electric shocks or fire etc.
 - ◆ The BM module must be installed on a firm and solid support which can withstand the weight of the module and the mounting surface must be horizontal plane. The BM module can be chosen to install in the ceiling, such as the ceiling of parlor, corridor, balcony, storeroom and etc
 - ◆ There is enough space for the installation and maintenance.
 - ◆ Avoid direct sunlight or other heat sources exist.
 - ◆ Do not install in location that is hot or humid for long periods of time.
 - ◆ Avoid the BM module installed in the bedroom and study, where these places need to be quiet.
 - ◆ BM module cannot be installed in the place of inflammable and explosive materials and severe dust, smoke and the other air pollution, such as the kitchen.
 - ◆ There is enough space to install drainage pipe, so that the condensed water can be discharged.
-



Caution!

Installation at the following places might lead to the air conditioner malfunction. If it is unavoidable, please contact the appointed service center.

- ◆ A place which is full of machine oil;
 - ◆ A region with saline-sodic soil near the sea;
 - ◆ A place where the sulphide fog exists, such as the sulphur spring;
 - ◆ A place where the high frequency facilities exist, such as radio equipment, electric welder and medical equipment;
 - ◆ An environment with special conditions.
-

3.2 Outline Dimension and Servicing Space of 89FBMJ205

1) Outline dimension

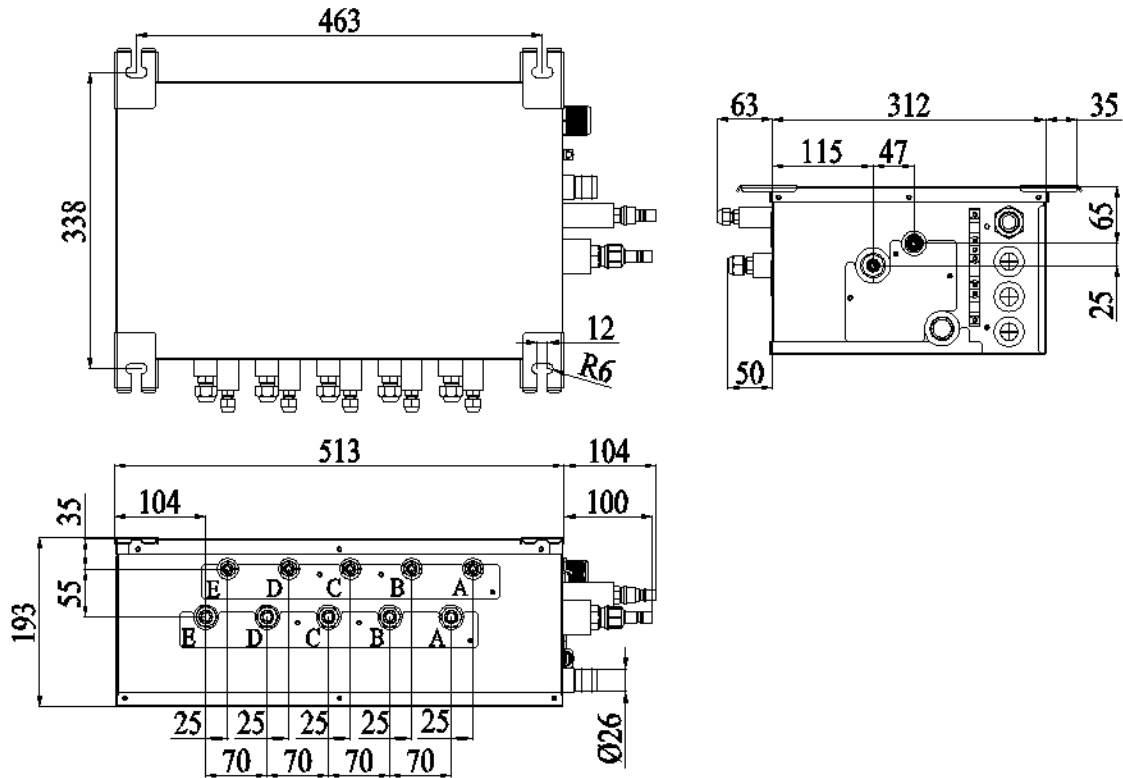
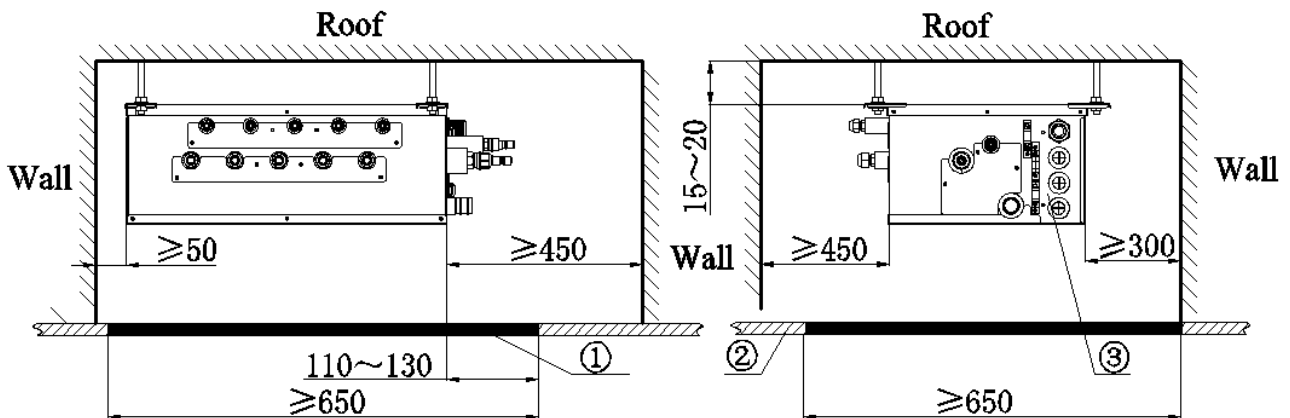

Fig. 3 (mm)

Table 3

Sorts	Indoor unit side (mm)	Outdoor unit side (mm)
Liquid pipe	Φ6.35	Φ9.52
Gas pipe	Φ9.52	Φ15.9

2) Installation and service space



NO.	①	②	③
Name	Servicing space	Ceiling	Electrical box side

Fig. 4 (mm)

4 Installation Instruction

- 1) Check the installation location and ensure it is strength and level. Otherwise, there should be enough space to install drainage pipe, so that the condensed water can be discharged.
- 2) Reference to the size of hanger metal and drill 4 holes in the installation location.
- 3) Hang the hanger bolts.

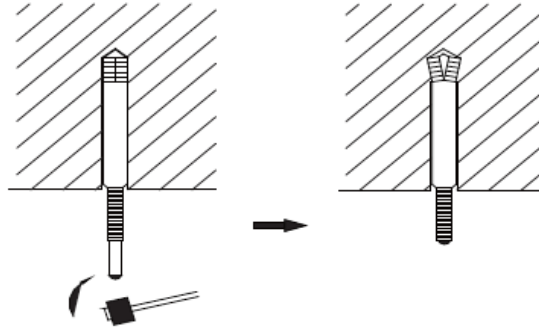

Fig. 5

- 4) Fix the modules securely with the hanger bolts. You can get the M10 or M8 hanger bolts, nuts and washers from the market.

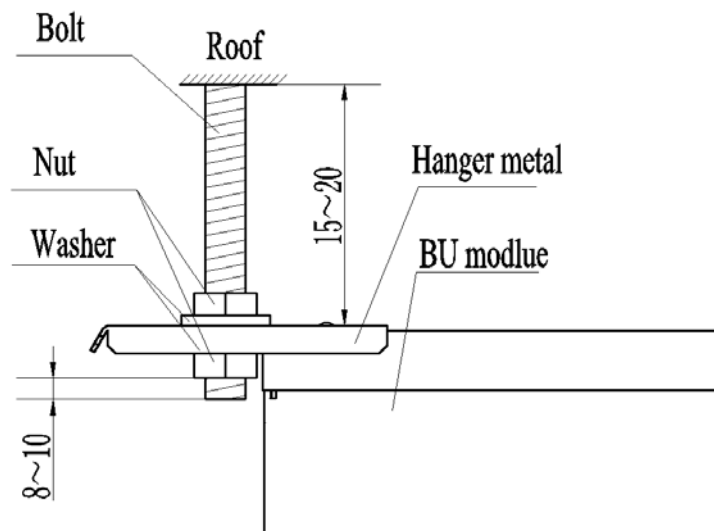

Fig. 6 (mm)

- 5) Adjusting the nuts position, so that the BM module should be level in front/back and left/right.

5 Installation of Refrigerant Pipes

5.1 Allowable Length and Drop Height of Connecting Pipe

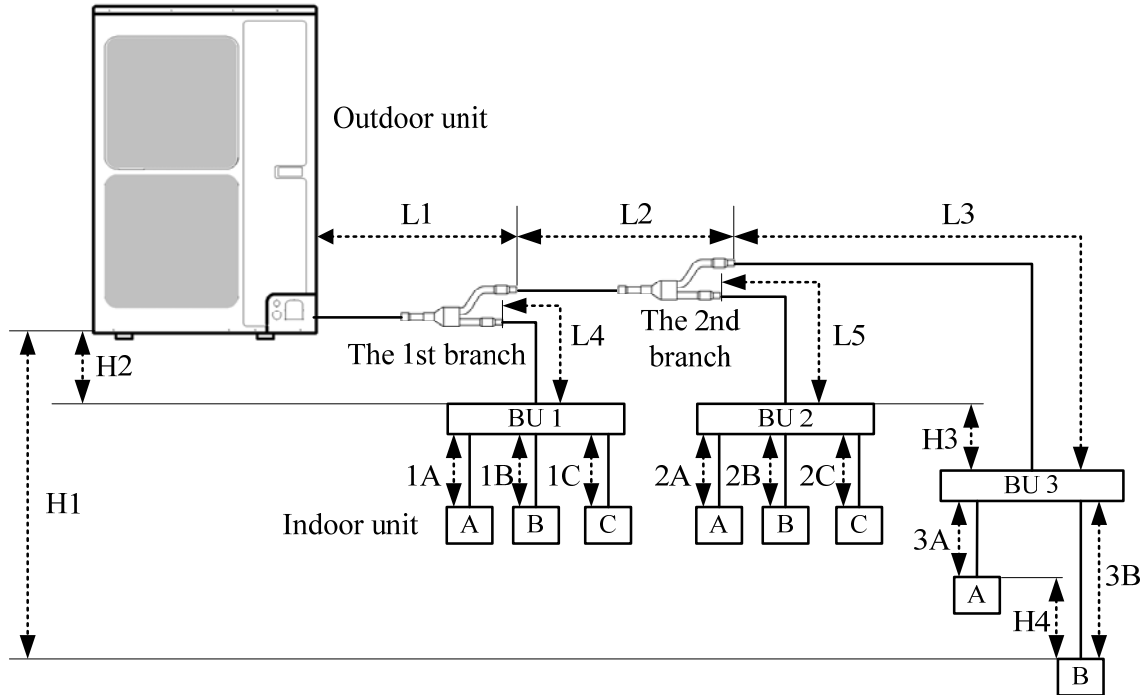

Fig. 7 (8 indoor units)

Table 4

The sorts		The pipes	Length (m)
Maximum allowable length	Total length between outdoor unit and BM modules	$L1+L2+L3+L4+L5$	≤ 55
	Total length between indoor unit and BM	86HS050J245	$1A+1B+1C+2A+2B+2C+$
		86HS060J249	$3A+3B$
	Between indoor unit and BM module	$1A;1B;1C;2A;2B;2C;3A;3B$	≤ 15
Between indoor unit and the 1st branch	$L4+1B;L2+L5+2A;L2+L3+3B$	≤ 40	
Maximum allowable length	Between outdoor and indoor units	$H1$	≤ 30
	Between outdoor units and BM	$H2$	≤ 30
	Between BM and BM modules	$H3$	≤ 15
	Between indoor and indoor units	$H4$	≤ 15
Minimum allowable length	Between outdoor and the 1st branch	$L1$	≥ 5
	Between BM and the branch	$L3;L4;L5$	as possible as short

◆ BM module should be placed within the level between the outdoor unit and indoor unit.

5.2 Installation of Piping Adapter

If the piping connection size of BM module does not match with that of the outdoor unit and indoor units, it should prevail with the piping connection size of the outdoor unit and indoor units. Install the optional piping adapters to the BM module, so that the piping connection size of BM

module can match with that of the outdoor unit and indoor units.

1) Piping adapter(Optional accessories)

Table 5

NO.	Name	Port A (mm)	Port B (mm)
1	Φ15.9→Φ19.05	Φ15.9	Φ19.05
2	Φ9.52→Φ12.7	Φ9.52	Φ12.7
3	Φ9.52→Φ15.9	Φ9.52	Φ15.9
4	Φ6.35→Φ9.52	Φ6.35	Φ9.52

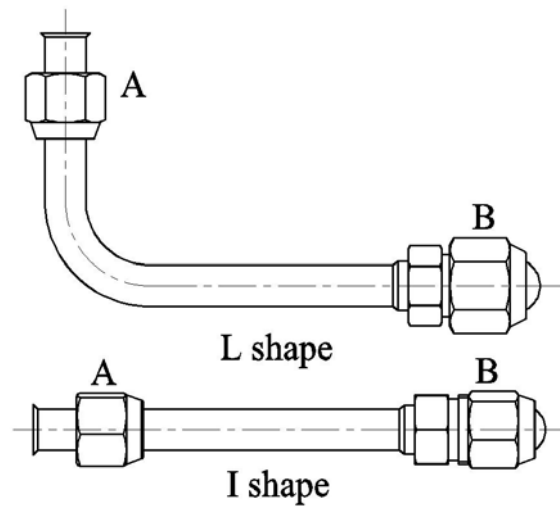

Fig. 8

2) Install the piping adapter

- ① Refer to the piping connection size of the outdoor unit and indoor units, the appropriate piping adapter should be adopted.
 - ② Align the flared end of copper tube with the center of pipe joint. Tighten the nuts with hands.
- 3) Sealing the unconnected port

If the port of BM module indoor side does not connected to one indoor unit, the port must be sealed to prevent refrigerant leaks. Please tighten the flaring nuts of the unconnected port with torque wrench until you hear a “click”.

5.3 Precaution for Connection

5.3.1 Precaution for connection

1) Pipe connections should be follow the following rules:

- ① Outdoor unit shall be installed close to the indoor unit, hence to minimize the length and bends of connection pipes.
 - ② The height gap of outdoor unit and indoor units should be as small as possible
- 2) The brazing operation must be strictly in accordance with the process requirements. During the installation, do not damage the pipeline.

5.3.2 The process of flaring

- ① Using the tube cutter to cut the connecting pipe in the appropriate place and remove the burrs.
- ② Install the nut before the flaring operation.
- ③ Check the flared portion, whether there is fractured or not.

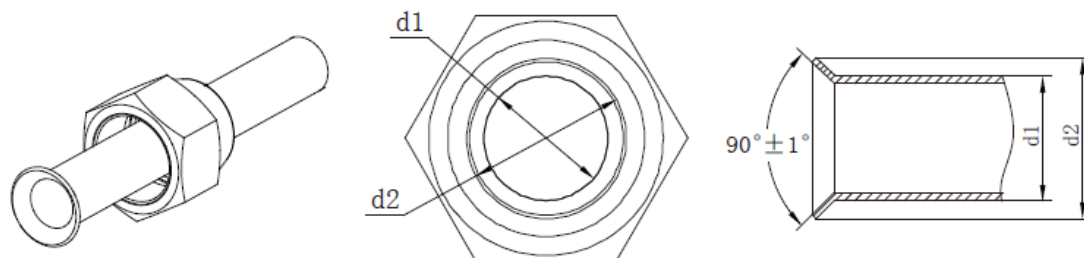

Fig. 9

5.3.3 Precaution for elbow operation

- ① The elbow operation could be done by hands. Be careful and do not damage the pipe.

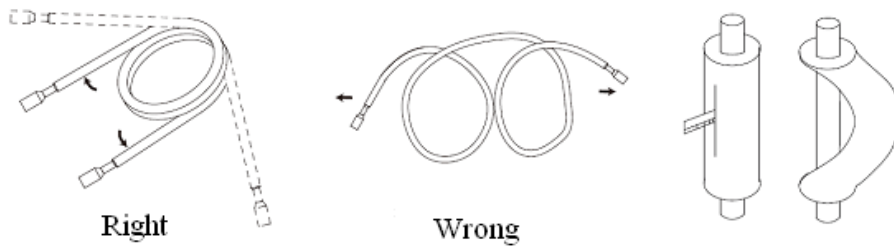

Fig. 10

- ② The bending diameter of the pipeline must be greater than 200mm. The connection pipe cannot often be bent or straightened. Otherwise it will harden and crack.
- ③ If the thermal insulation of the refrigerant pipe is not removed, please do not bend the pipe. Otherwise, it maybe leads the pipe to crack. It is better to make an incision with a knife in the thermal insulation and removes it. After elbow operation is finished, recover the thermal insulation with binding band.

5.3.4 The process of install refrigerant pipes

- ① Remove the screw caps from the pipes.
- ② Align the flared end of copper tube with the center of pipe joint. Tighten the nuts by hands. (If the flared end of copper tube and the center of pipe joint are not in coaxial, it is hard to tighten the nuts by hands, please do not tighten it with spanners, because the screw thread may be broken by force).
- ③ Tighten the flaring nuts with torque wrench until you hear a “click”. (The spanner and torque wrench should be perpendicular to the refrigerant pipeline).
- ④ The following table for the torque required to tighten the nuts.

Table 6

Pipe diameter	Thickness of copper tube	Tightening torque
Φ6.35 mm	≥0.8 mm	15~30 N·m
Φ9.52 mm	≥0.8 mm	35~40 N·m
Φ12.7 mm	≥0.8 mm	45~50 N·m
Φ15.9 mm	≥1.0 mm	60~65 N·m
Φ19.05 mm	≥1.0 mm	70~75 N·m

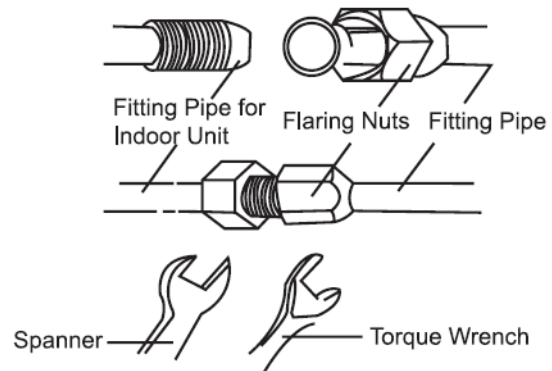

Fig. 11

! Caution!

- ◆ During the connection of the indoor unit and BM module to the refrigerant pipe, never pull any joints of the indoor unit and the BM module by force; otherwise the capillary pipe or other pipe may crack, which then would result in leakage.
- ◆ The refrigerant pipe should be supported by brackets, that is, don't let the unit withstand the weight of it.
- ◆ For the inspire Inverter system, each pipe should be labeled to tell which system it belongs to avoid mistaken inaccurate piping.

6 Electrical Wiring Work

6.1 Wiring Connection

Precept 1

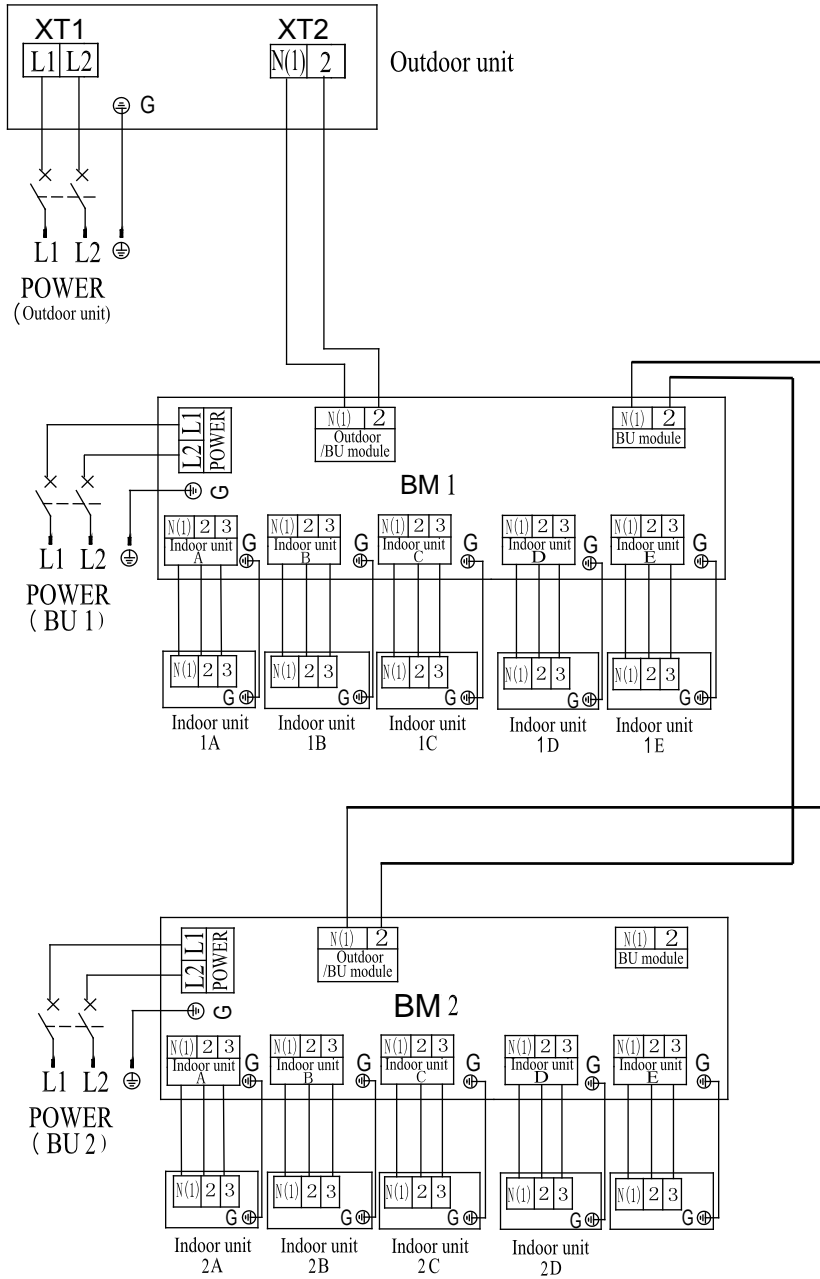

- ◆ The “L1” and “3” terminals are connected to the live wire, the “L2”, “N(1)” terminals are connected to the neutral wire and the “2” terminal is connected to the transmission line.

Fig. 12

6.2 Requirements of Power Circuit and Cable

Table 7

Frequency		60Hz
Phase and voltage	Outdoor unit	1Ph, 208/230V
	BM module	1Ph, 208/230V
Recommended cable of outdoor unit (Pieces × Sectional area)	86HS050J245	3×6.0 mm ²
	86HS060J249	
Recommended cable of BM module (Pieces × Sectional area)		3×0.75 mm ²
Transmission line (Pieces × Sectional area)		2×1.5 mm ²
Recommended cable of indoor unit (Pieces × Sectional area)		4×0.75mm ²
Capacity of the air switch	86HS050J245	40A
	86HS060J249	40A
	BM module	10A

Note:

- ◆ The total length of the transmission line between the outdoor unit and the furthest BM module is not more than 55m. Otherwise, the system cannot work possibility.
- ◆ The specifications of the power cable and transmission line listed in the table above are determined based on the maximum power (maximum amps) of the unit.
- ◆ The specifications of the power cable listed in the table above are applied to the conduit-guarded multi-wire copper cable (like, YJV copper cable, consisting of PE insulated wires and a PVC cable jacket) used at 40°C and resistible to 90°C. If the working condition changes, they should be modified according to the related national standard.
- ◆ The specifications of the air switch listed in the table above are applied to the breaker with the working temperature at 40°C. If the working condition changes, they should be modified according to the related national standard.
- ◆ The length of the recommended power cable should be less than 15 meters; otherwise, the diameter of the power cable is not enough.
- ◆ Mentioned power cable and transmission line length is just a reference value. It may be different depending on the condition of installation, humidity or materials, etc.
- ◆ An all-pole disconnection switch having a contact separation of at least 3mm in all poles should be connected in fixed wiring.

6.3 Ground Requirements

- ◆ The air conditioner is classified into the Class I appliances, so its ground ways must be reliable.
- ◆ The ground wire must be fixed on the screw hole with the sign as the right figure. 
- ◆ The yellow-green wire of the air conditioner is the ground wire and must be fixed by the tapping screw. And it cannot be used for other purpose or cut off. Otherwise, it will cause the hazard of electric shock.
- ◆ The reliable ground terminal should be provided and the ground wire cannot be connected to

any of the following places: a. Water pipe; b. Coal gas pipe; c. Sewage pipe; d. Lightning rod
e. Telephone line f. Other unreliable places considered by a professional.

6.4 Precautions of Electrical Wiring Work

- ◆ The ground connection should be reliable and the ground wire should be connected to the dedicated device of the building by the professional.
- ◆ The electric installation should be carried out by the professional as instructed by the local laws, regulations and also this manual.
- ◆ The air switch coupled with the leakage current protection switch must be equipped in the circuits, which is of enough capacity and of both magnetic and thermal tripping functions in case of the short circuit and overload.
- ◆ The electrical work should use a cable length enough to cover the entire distance with no connection. If it is unavoidable, please make sure the connection should be reliable, the external forces will not act on the wires and the joint is not bared. Otherwise it will cause electrical shock or fire etc.
- ◆ The power cable with the rated voltage and exclusive circuit for the air conditioning should be used.
- ◆ Do not pull the power cable by force after it is installed.
- ◆ The diameter of the power cable should be large enough and once it is damaged, it must be replaced by the dedicated one.
- ◆ The multi-wire copper cable should be used for the power cable and the transmission line.

6.5 Precaution of Laying Wires

- 1) Use a wire stripper to strip off a length of the insulation layer at the end of the wires;
- 2) Loosen the screws on the terminal block of the air conditioner;
- 3) Press the ends of the cable tightly onto the round terminals corresponding to the size of the screws.
- 4) Pass the screw through the round terminals and fix it onto the terminal block.

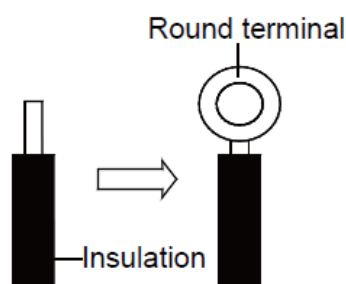
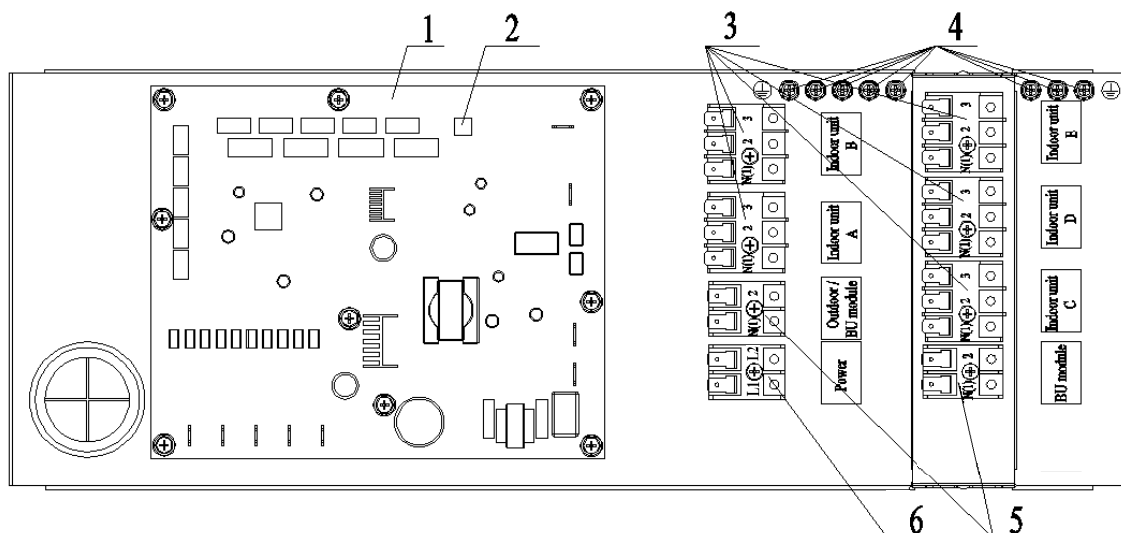

Fig. 13

6.6 Procedures for Electrical Wiring Work

- 1) Unscrew the electrical equipment plate.
- 2) The structure of behind the electrical equipment plate.



89FBMJ205

NO.	1	2	3
Name	Printed circuit board	DIP switch	Terminal black for indoor unit power supply
NO.	4	5	6
Name	Ground screw	Terminal black for transmission line	Terminal black for BM module power supply

Fig. 14

- 3) Let the power cable and transmission line go through the rubber ring. In order to protect the power cable and transmission line from damaging by the hole, the rubber ring cannot fall from that, otherwise, it may cause electrical shock or fire etc.
 - 4) Connect the power cable of the BM module to the L1, L2 terminals with the sign of Power and as well as the ground screw.
 - 5) Connect the transmission line of the BM module to the N(1), 2 terminals with the sign of Outdoor /BM module.
 - 6) If the power cable need to be connected to the other BM module, please connect the extra line to the L, N terminals with the sign of BM module Power and as well as the ground screw.
 - 7) If the transmission line need to be connected to the other BM module, please connect the extra line to the N(1), 2 terminals with the sign of BM module.
 - 8) Connect the power cable of the indoor unit to the N(1), 2 and 3 terminals with the sign of Indoor unit A (B, C, D and E) and as well as the ground screw.
 - 9) Fix the power cable and transmission line firmly by cable fixing clip.
 - 10) Screw the electrical equipment plate.
-

! Caution!

- ◆ The transmission line and the power cable must be separated and separated with an interval of at least 2cm; otherwise it may be result in communication problem.
- ◆ Confirm the each cable connected to the terminal screw is exactly and securely after finishing the electric work.
- ◆ Fix each ground wire separately with the ground screw.
- ◆ When connecting indoor units, make sure to connect refrigerant pipes and power cables to the same connection ports marked with matching signs (A, B, C, D and E).
- ◆ If the connecting wire is connected to the terminal incorrectly, the unit will not work normally.

6.7 Instructions for DIP Switch

- ◆ 2 digits DIP is adopted to assign the address when using multi-BM modules and the address cannot be repeated in the same unit.
- ◆ One outdoor unit can connect to no more than 3 BM modules.
- ◆ “ON” side means "ON" and the opposite side represents "OFF". (Note: The black part is lever.)

Table 8

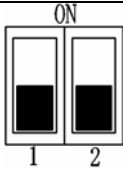
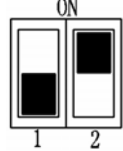
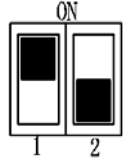
Number	DIP Code		Icon	Address
	DIP 1	DIP 2		
1	OFF	OFF		BM 1
2	OFF	ON		BM 2
3	ON	OFF		BM 3

7 Design of Drainage Pipeline

7.1 Installation of Drain Hose

- 1) Remove the rubber stopper of drain hole.
- 2) Connect the drain hose to the drain hole of BM module.
- 3) The drain hose should be kept at 5~10 degrees of gradient to facilitate discharge of the condensing water. Take care that does not exert too much force on the hose.
- 4) Thermal insulation materials should be placed at the joints of the drain hose so as to prevent from dew condensation. Fix the drain hose firmly by binding band.

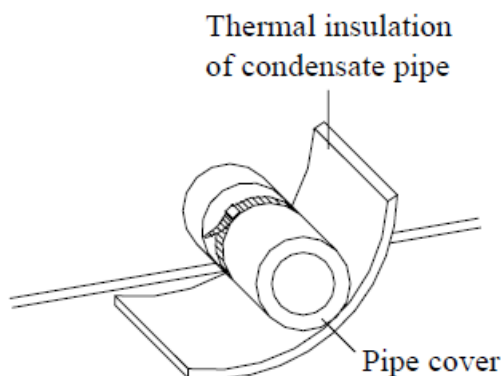

Fig. 15

- 5) The end of the drain hose should be inserted into the hole of drainage pipeline.

7.2 Design of Drainage Pipeline

- 1) The drainage pipeline should be kept at a certain gradient ($1/50$ — $1/100$) so as to avoid bulges of pipes where there might be water bends.
- 2) The drainage pipeline is form of the hard PVC pipes for common purposes which can be purchased locally. The diameter of the PVC pipes is not less than 31mm and the pipeline should be fixed as close to the BM module as possible.
- 3) Insert the drain hose into the drain hole of drainage pipeline. Use binding band to fix it tightly. It is not allowed to use adhesive glue to join the drain hose to the drainage hole.
- 4) When the drainage pipeline is laid for a couple of units, the position of the shared pipeline should be approximately 100mm lower than the drainage hole of each module. In this case, some special-purpose pipes with thicker walls will be used.
- 5) At intervals of about 1 meter, fix the drain pipes to the wall with brackets, not floating in the air.

8 Test Operation

After all the installation has been accomplished, follow the “operation test” as described in the outdoor unit owner’s manual.

9 Troubleshooting



Caution!

- ◆ In the event of abnormal conditions (like stinky smell), please shut off the power supply immediately and then contact the appointed service center; otherwise, the abnormal running would damage the air conditioner and also would cause electric shock or fire etc.
- ◆ Do not repair the air conditioner personally but instead of contact the professionally skilled personnel at the appointed service center, as the incorrect repair would cause electric shock or fire etc.

Errors	Indicating LED flashing times			Indoor unit error code	Outdoor unit error code
	Yellow LED	Green LED	Red LED		
BM 1 is connected	Flash 1 time				
BM 2 is connected	Flash 2 times				
BM 3 is connected	Flash 3 times				
Indoor unit A is connected		Flash 1 time			
Indoor unit B is connected		Flash 2 times			
Indoor unit C is connected		Flash 3 times			
Indoor unit D is connected		Flash 4 times			
Indoor unit E is connected		Flash 5 times			
Indoor unit A gas tube temperature sensor error			Flash 1 time	b7	b7 indoor unit address
Indoor unit A liquid tube temperature sensor error			Flash 2 times	b5	b5 indoor unit address
Indoor unit B gas tube temperature sensor error			Flash 3 times	b7	b7 indoor unit address
Indoor unit B liquid tube temperature sensor error			Flash 4 times	b5	b5 indoor unit address
Indoor unit C gas tube temperature sensor error			Flash 5 times	b7	b7 indoor unit address
Indoor unit C liquid tube temperature sensor error			Flash 6 times	b5	b5 indoor unit address
Indoor unit D gas tube temperature sensor error			Flash 7 time	b7	b7 indoor unit address
Indoor unit D liquid tube temperature sensor error			Flash 8 times	b5	b5 indoor unit address
Indoor unit E gas tube temperature sensor error			Flash 9 time	b7	b7 indoor unit address
Indoor unit E liquid tube temperature sensor error			Flash 10 times	b5	b5 indoor unit address

10 After-Sales Service

If there is any quality or other issue, please contact the after-sales service center.

Thank you for Choosing



www.delta-dct.com

